

# PHARMLOGISTICS - modular systems as per ISO norms

## Modular system supports better cost-effectiveness

Modular design allows using internal space of a cabinet to maximum effect. Tray spacing is divisible by 64 mm.

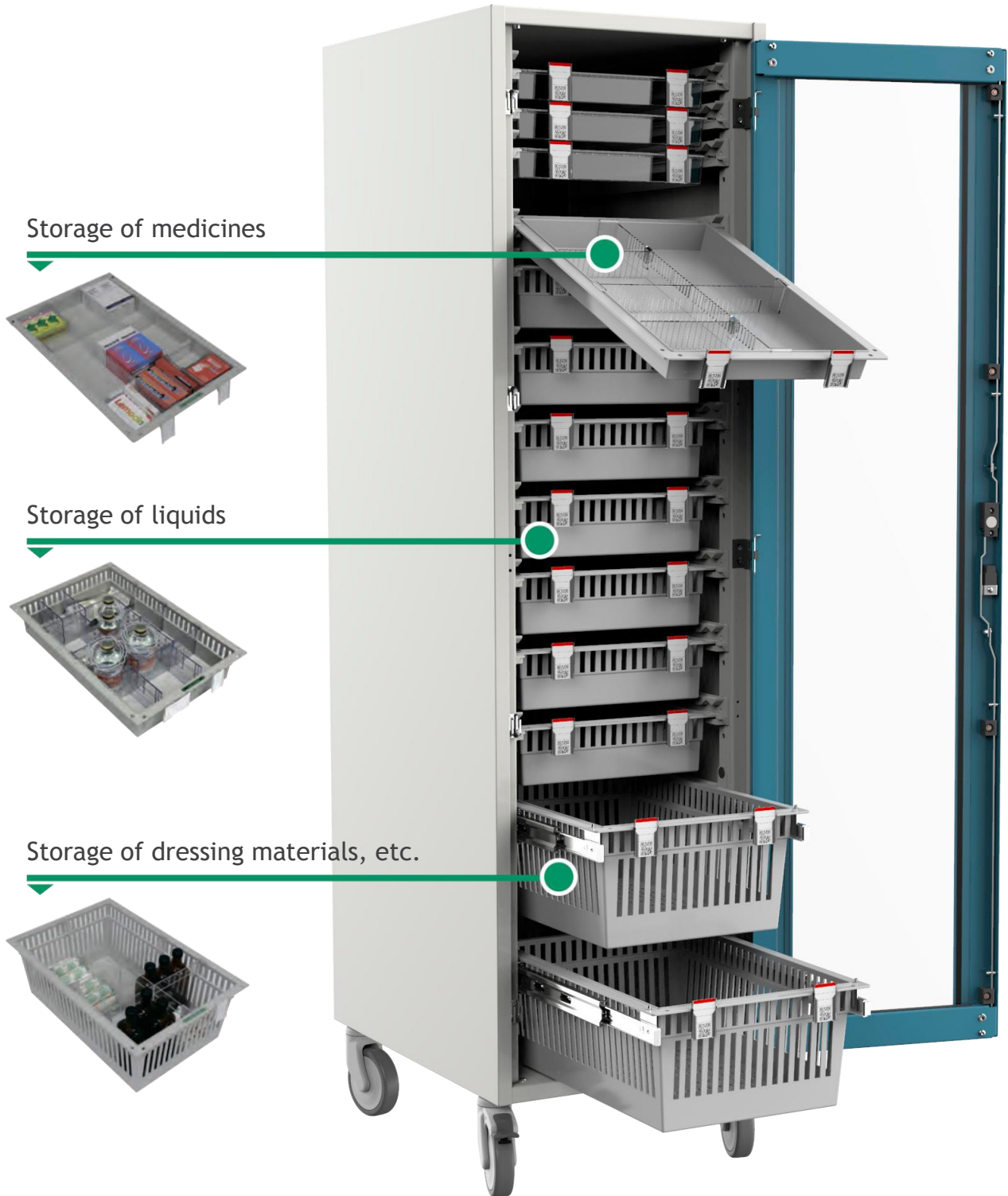

Storage of medicines



Storage of liquids

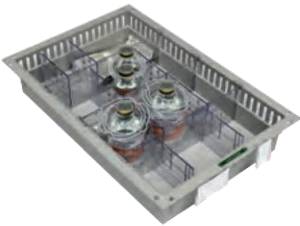

Storage of dressing materials, etc.



Flexible dividers allow saving up to 30% of tray space.



■ H+H FlexTray ABS trays (enclosed type)	page 4
■ H+H FlexModul ABS trays (open type)	page 4
■ H+H PC trays (FlexTray/ FlexModul)	page 5
■ H+H FlexBasket baskets (ABS/ PC)	page 5
■ Cross-headed divider elements	page 6
■ Draw-out mechanism stoppers	page 7
■ ISO tray covers	page 8
■ H+H System single-use seals	page 8
■ Boxes of ISO trays (stackable type)	page 9
■ Tray personalization plates	page 10
■ Magnet marking bars	page 10
■ Marking boards	page 11
■ Board labels	page 11
■ Sliding ISO dividers	page 12
■ ISO PC bracket (sliding divider pin)	page 12
■ Sets of sliding ISO dividers	page 13
■ Plastic ABS slides of ISO trays	page 14
■ Metal slides of ISO trays	page 14
■ Wall-mounted ABS panels of ISO trays	page 14
■ Telescopic slides of ISO trays	page 15
■ Sliding trays	page 16
■ Fixed trays (adjustable type)	page 16
■ Storage boxes with handles	page 16
■ ISO-M baskets (metal)	page 17
■ Dividers of ISO-M baskets (metal)	page 17

## ■ H+H FlexTray ABS trays (enclose type)

### Distinctive features:

- Material: Grey ABS plastic (resistant to scratches and dirt).
- Walls and bottom are enclosed type (without perforation).
- Sealed structure allows using a tray as an insulated container for transportation of different medicines (liquids, small items, etc.).

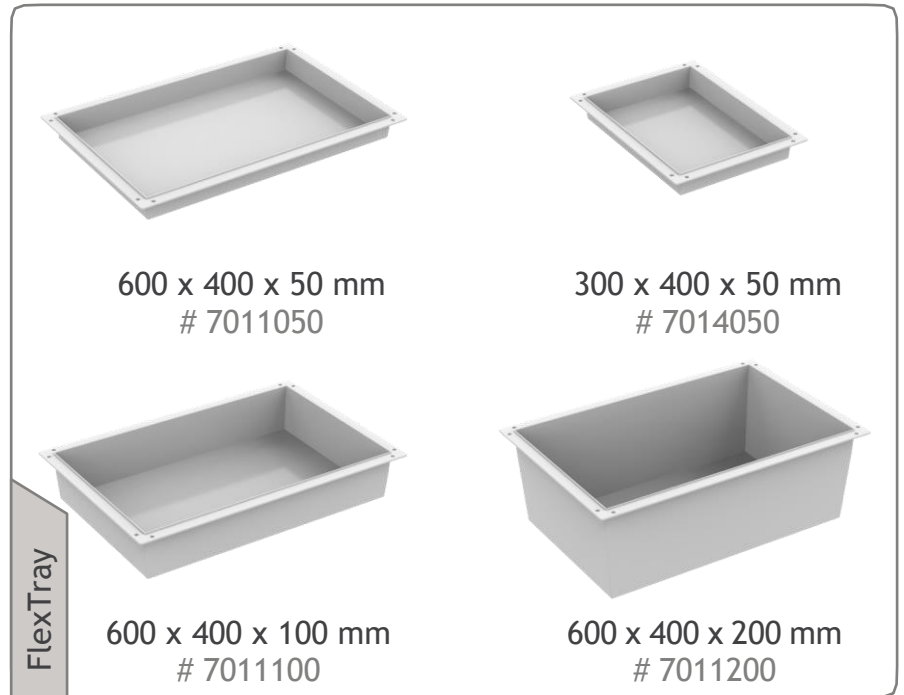

## ■ H+H FlexModul ABS trays (open type)

### Distinctive features:

- Material: grey ABS plastic (resistant to scratches and dirt).
- Walls are open type (perforated); bottoms are enclosed type (without perforation).
- Tray design allows locating fixed dividers with spacing of 20 mm.
- Enclosed bottoms 50 mm in height prevent leakage and drop-out of small items.

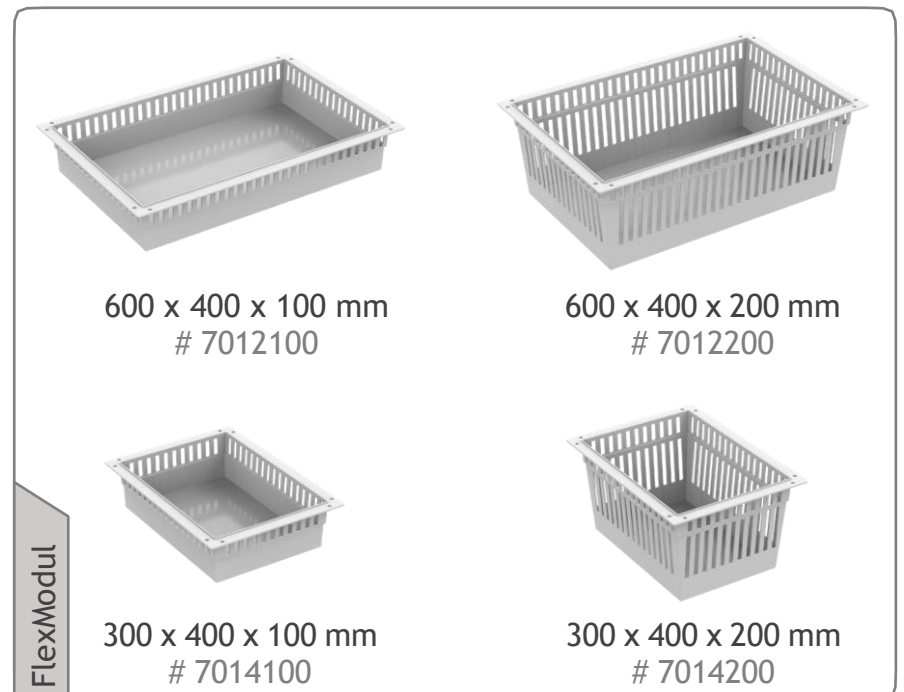

## H+H PC (FlexTray/ FlexModul) trays

### Distinctive features:

- Material: transparent polycarbonate. The material is crash-proof and resistant to scratches and short-time sterilization. It easily bears sanitary treatment.
- Transparent structure allows storing of medicines in a clearly visible way and makes it easier to search and keep different items.

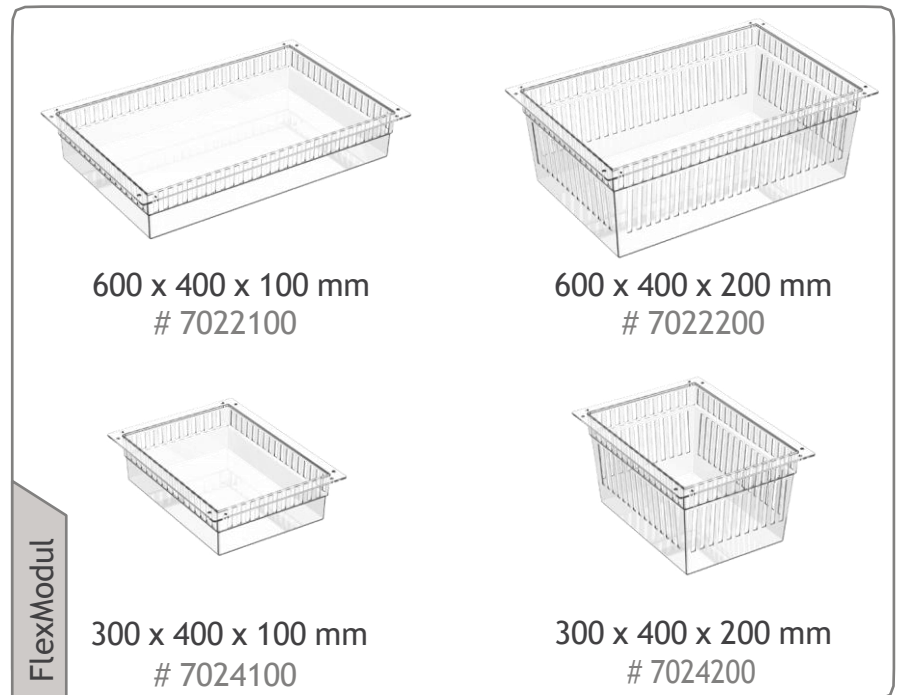
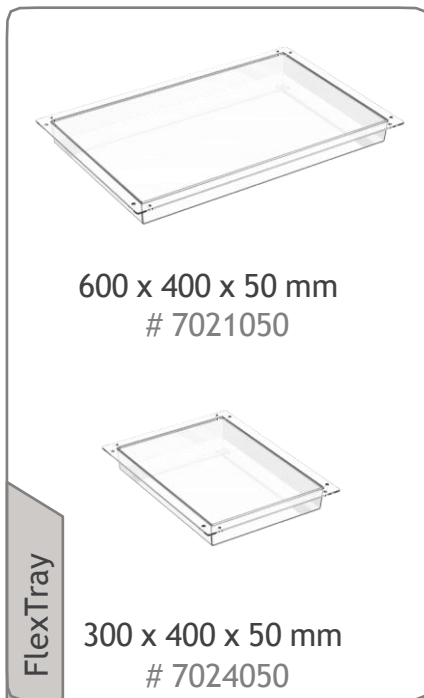

## H+H FlexBasket (ABS/ PC) baskets

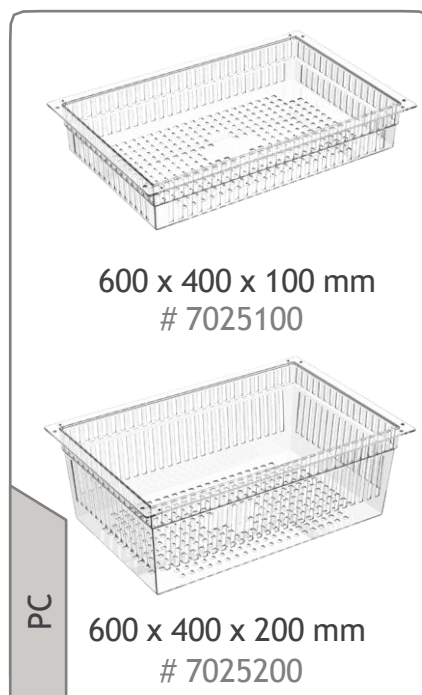
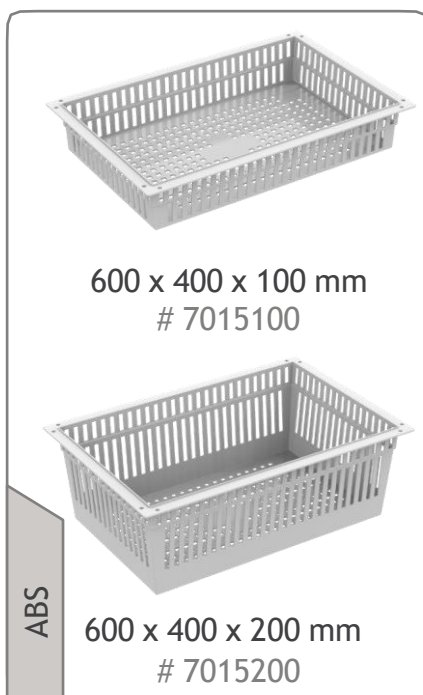

### Distinctive features:

- Material: grey ABS plastic/ transparent polycarbonate.
- Walls and bottoms are open type (perforated).
- Perforated design of a basket allows reducing module's weight up to 20 % (in comparison with enclosed type trays).





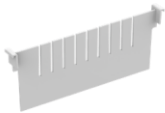
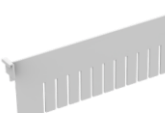
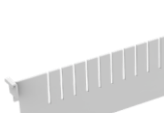
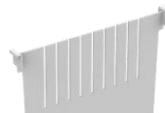

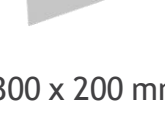
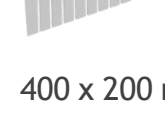
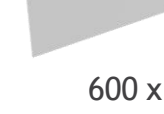

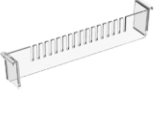

■ Cross-headed divider elements (ABS/ PC)

**ABS**

		
300 x 50 mm # 7810106	400 x 50 mm # 7810105	600 x 50 mm # 7810104
		
300 x 100 mm # 7811206N	400 x 100 mm # 7811205N	600 x 100 mm # 7811204N
		
300 x 200 mm # 7811306	400 x 200 mm # 7811305	600 x 200 mm # 7811304

**PC**

		
300 x 50 mm # 7810103	400 x 50 mm # 7810102	600 x 50 mm # 7810101
		
300 x 100 mm # 7811203N	400 x 100 mm # 7811202N	600 x 100 mm # 7811201N
		
300 x 200 mm # 7811303	400 x 200 mm # 7811302	600 x 200 mm # 7811301

## Purpose:

- Stoppers allow fixing a module in the limit (pulled-out) position under  $\alpha$  angle (towards the horizontal position).
- Stoppers prevent a module from dropping out from a cabinet while being pulled out.

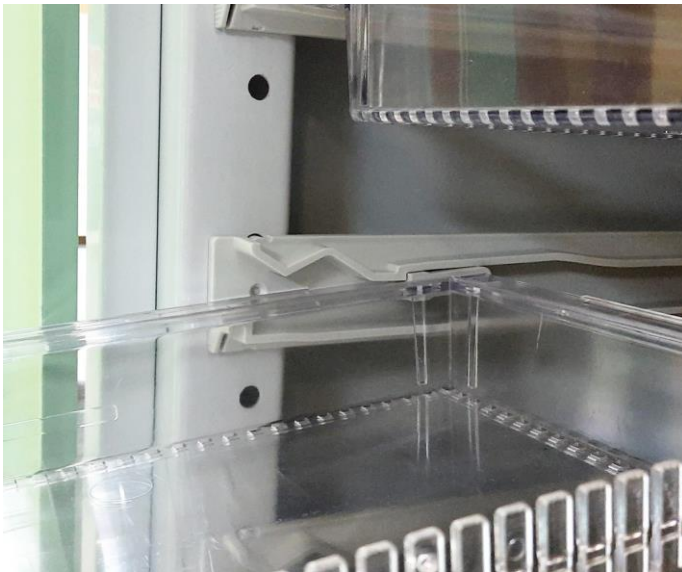

Position #1 (upper support)  
Tray slope  $\alpha$  angle: 50



Position #2 (lower support)  
Tray slope  $\alpha$  angle: 300

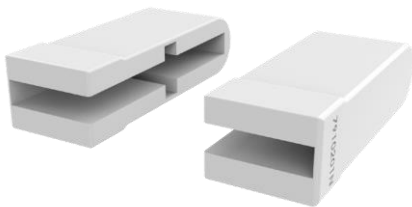

ISO 3 stopper  
# 7910201N

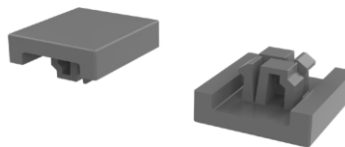

ISO 4 stopper  
# 7910101

### Distinctive features:

Double-side stopper. Being placed in plastic slides, it reliably fixes a tray in two positions: ( $\alpha$ : 50 and  $\alpha$ : 300)

This item is not intended for joint use with a cover and in case a tray is mounted on full extension ball slides. In these cases stoppers shall be removed.

### Distinctive features:

One-side stopper. This item shall be mounted at a tray from above or below. Being placed in plastic slides, it reliably fixes a tray in two positions: ( $\alpha$ : 50 and  $\alpha$ : 300)

This item can be used in combination with a cover. It shall not be used in case a tray is mounted on full extension ball slides.

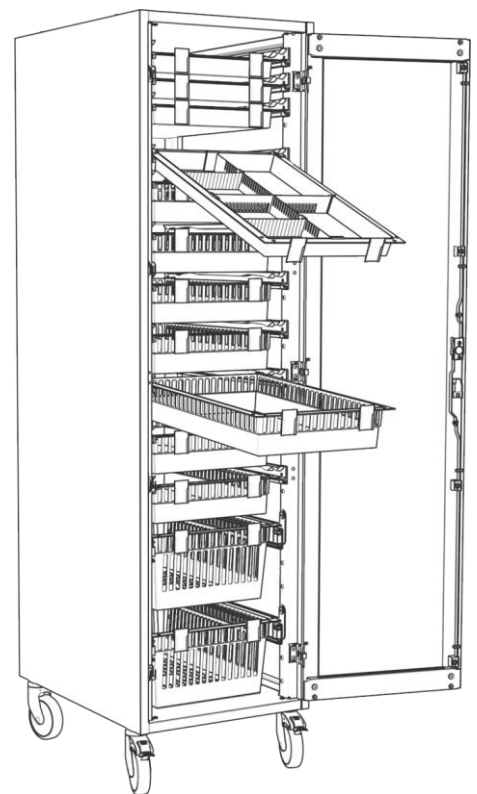

## ISO tray covers

### Distinctive features:

- Two material options: grey ABS plastic and transparent polycarbonate.
- Sealing option: yes.
- Slots for dividers' arrangement: yes (applicable for H+H FlexTray system).

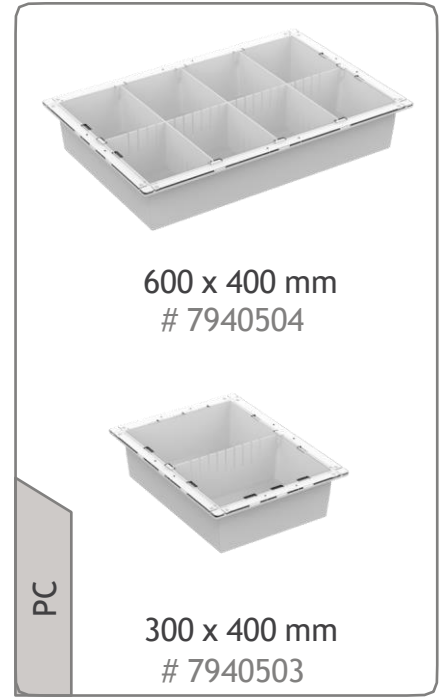
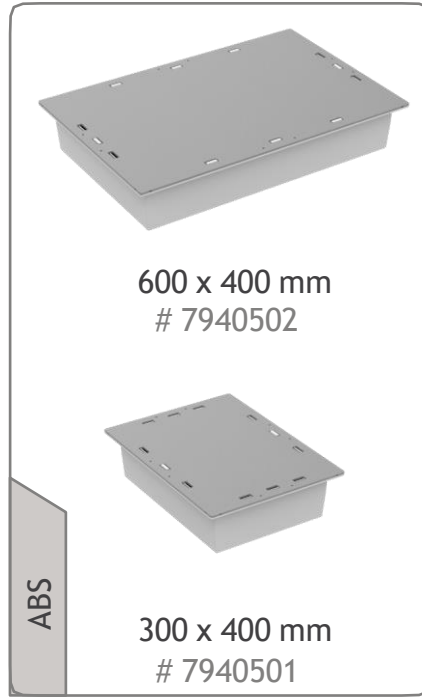

## H+H System single-use seals

### Distinctive features:

- Material: colored plastic (red/ green).
- Two seal body options (short/ long).
- Each seal is provided with unique tags.

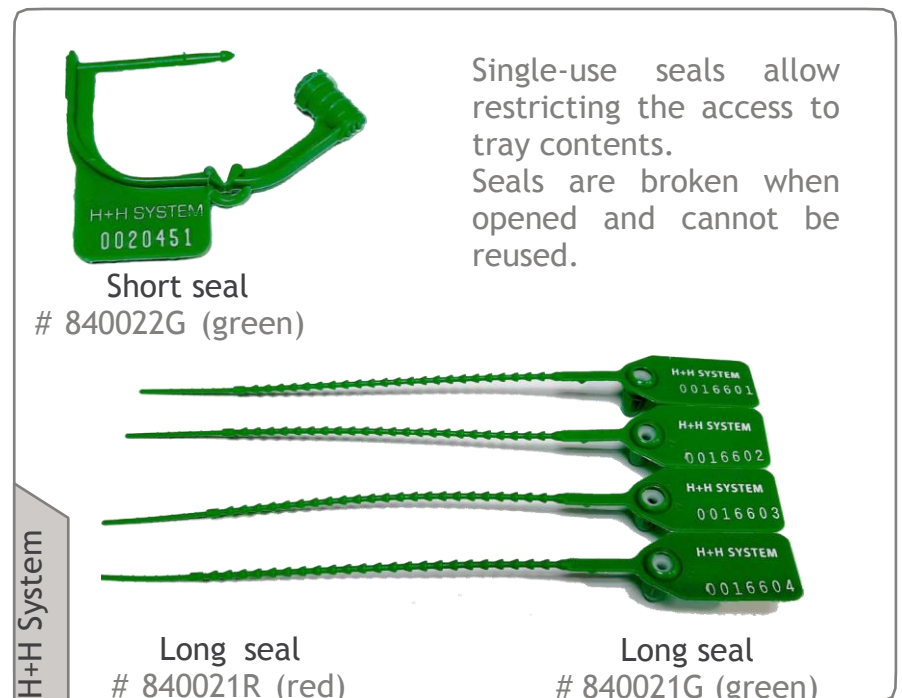



## Boxes of ISO trays (stackable type) ■

### Distinctive features:

- Material: transparent polystyrene, which is resistant to sanitary treatment.
- Sealed body. Boxes can be stacked for more convenient transportation.
- Two height options (for ISO trays 50 and 100 mm in height).

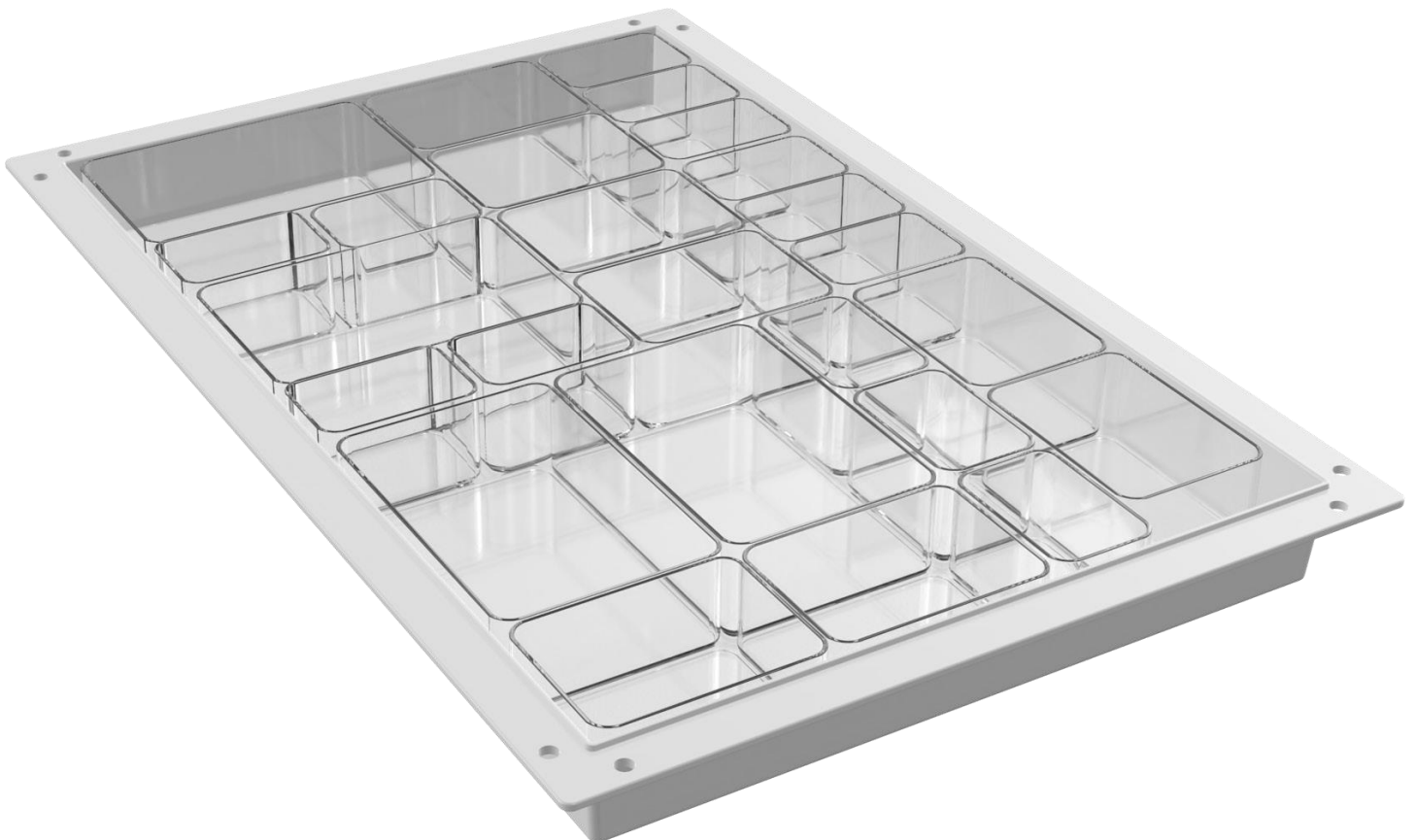
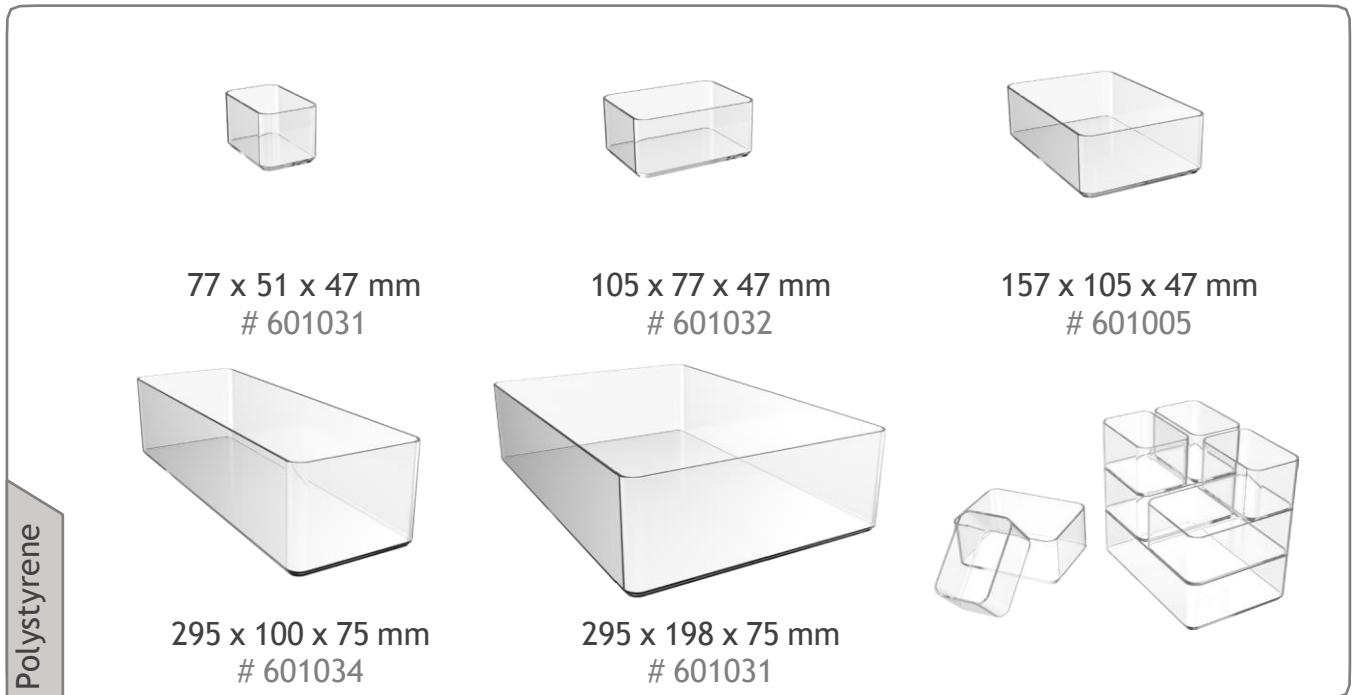

## Tray personalization plates

### Distinctive features:

- Bar material: transparent polycarbonate.
- Two options: printed label + protective bar/ printed bar.
- This item is suitable for all modules (FlexTray, FlexModul and FlexBasket series).



Transparent plate  
# 7910501

MOQ: 1 pce.

Your logo

Printed plate  
# 7910502

Printing with 1 color at option.  
MOQ: 200 pcs.

PC

## Magnet marking bars

### Distinctive features:

- Bars are attached to a body by means of neodymium magnets (items can be placed at both inner and outer sides of a cabinet).
- Flexible adjustment (bars may be located at convenient height with no additional fasteners).



Label bar (PVC)  
# 7972350M

Board bars  
# 7970501M

Vertical A4 pocket (APET)  
# 44198M

Horizontal A4 pocket (APET)  
# 44197M

## Distinctive features:

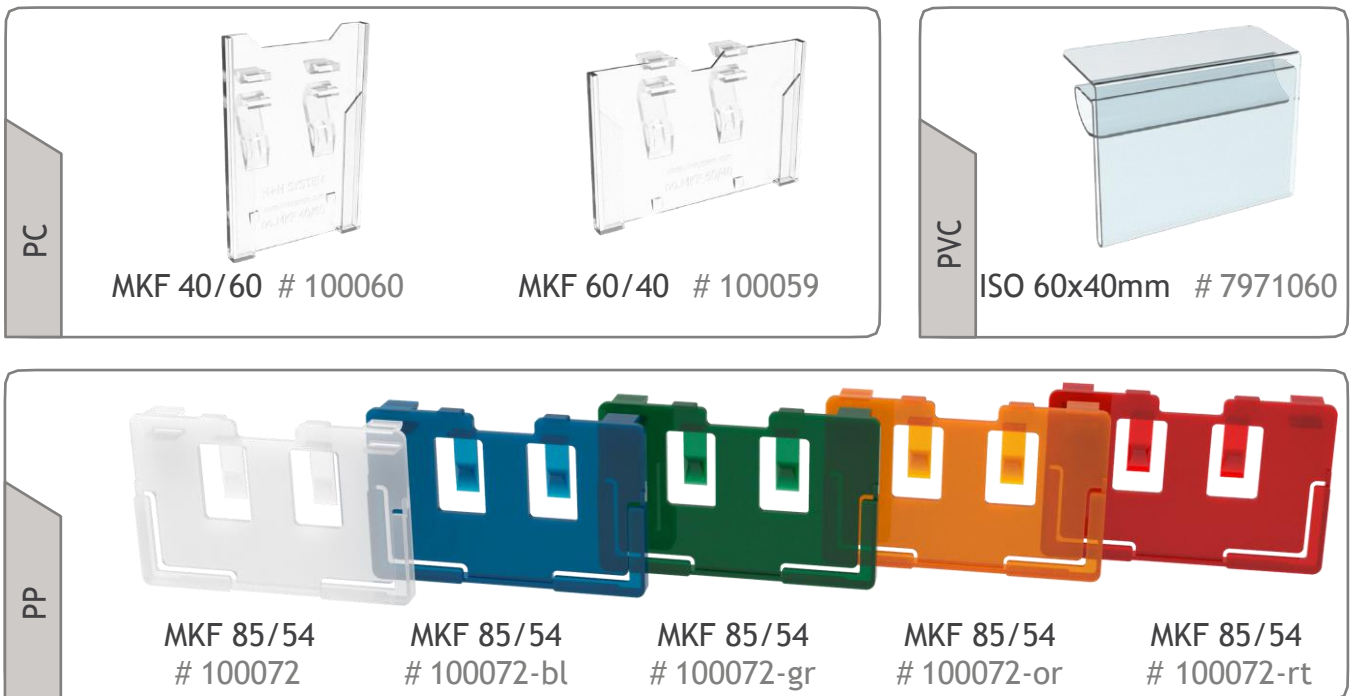

- Boards are made of plastic materials (PC, PVC, PP), which are resistant to sanitary treatment.
- Several options of board attachment.
- Standard card size: 40x60 mm and 85x54 mm.



## Board labels ■

### Distinctive features:

- Card (base) material: white plastic. Plastic thickness: 0.5 mm.
- Label materials: adhesive paper (3 color options)/ cardboard (white).
- Labels are adapted for printing at inkjet and laser printers. Labels are supplied in sheets.

 <p>Card (base)</p> <p>85x54x0.5 mm # K100187</p> <p>60x40x0.5 mm # K100185</p> <p>Material: plastic Color: white MOQ: 1 pce.</p>	 <p>Label ISO 60 x 40 mm</p> <p>yellow # K100191-gb red # K100191-rt white # K100191-ws</p> <p>MOQ: 1 sheet (25 labels).</p>	 <p>Label 85 x 54 mm</p> <p>white # 100076</p> <p>Material: 185 g cardboard Sheet format: A4 MOQ: 1 pack (10 sheets)</p>
--	---	---

## ■ Sliding ISO dividers

**Distinctive features:**

- Material: transparent polycarbonate.
- These items are to be mounted on cross-headed divider elements.
- Length shall be selected individually during the installation (reduction be means of removal of segments).

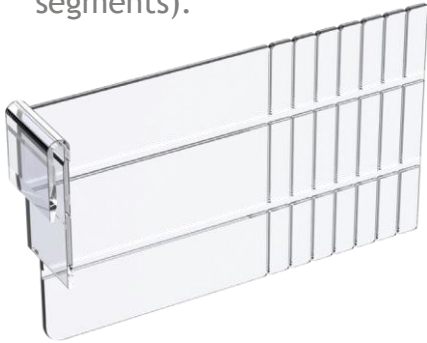

Height	Length	Article	Number
45 mm	10...170	106 GS/170	# 241302
100 mm	100...170	100/100 GL/170	# 240820

Segments shall be removed manually on table edge without involvement of special equipment. Segment width: 10 mm.

## ■ ISO PC bracket (sliding divider pin)

**Distinctive features:**

- Material: transparent polycarbonate.
- This item shall be installed on tray edge or cross-headed divider elements.
- Brackets arrange individual dividing system and fix the dividers.



Description	Number
Left ISO PC bracket, 50	# 7800101
Left ISO PC bracket, 100	# 7800201

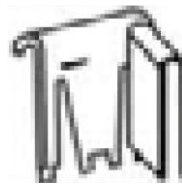

Description	Number
Right ISO PC bracket, 50	# 7800102
Right ISO PC bracket, 100	# 7800202

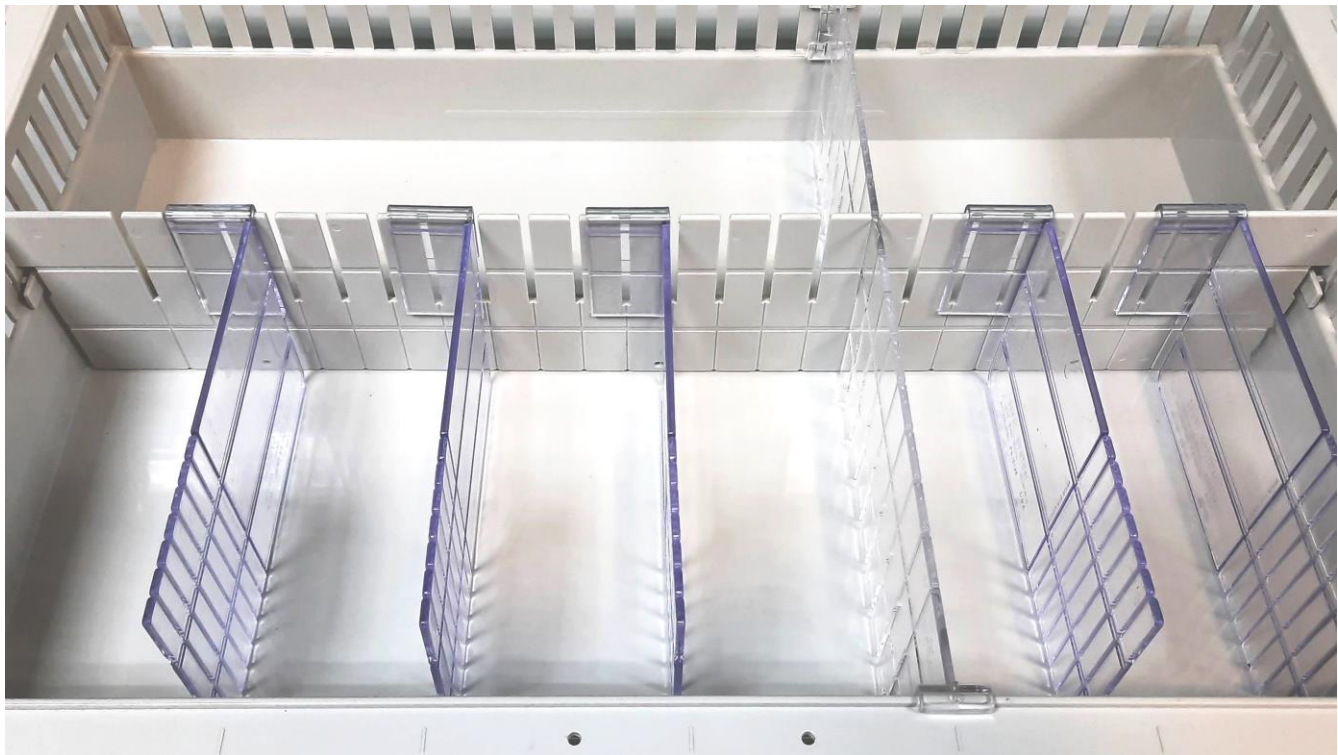

Height: 50

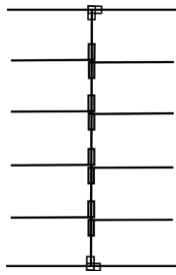

# 500610  
MED-insert ISO  
400x600x50 mm  
10 modules  
2 longitudinal rows  
8 dividers.

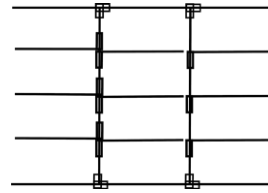

# 500615  
MED-insert ISO  
600x400x50 mm  
12 modules  
3 transversal rows  
9 dividers.

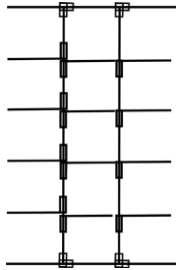

# 500611  
MED-insert ISO  
400x600x50 mm  
15 modules  
3 longitudinal rows  
12 dividers.

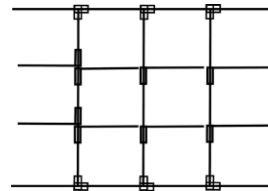

# 500620  
MED-insert ISO  
600x400x50 mm  
12 modules  
4 transversal rows  
8 dividers.

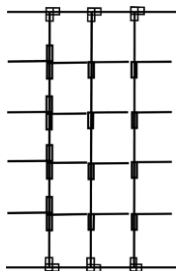

# 500612  
MED-insert ISO  
400x600x50 mm  
20 modules  
4 longitudinal rows  
16 dividers.

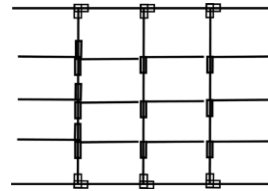

# 500616  
MED-insert ISO  
600x400x50 mm  
16 modules  
4 transversal rows  
12 dividers.

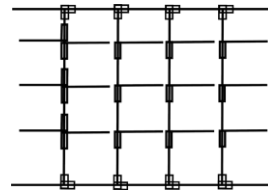

# 500617  
MED-insert ISO  
600x400x50 mm  
20 modules  
5 transversal rows  
15 dividers.

Height: 100

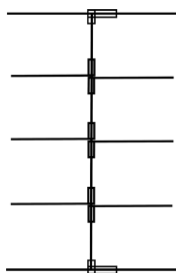

# 500613  
MED-insert ISO  
400x600x100 mm  
8 modules  
2 longitudinal rows  
6 dividers.

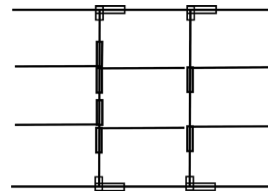

# 500618  
MED-insert ISO  
600x400x100 mm  
9 modules  
3 transversal rows  
6 dividers.

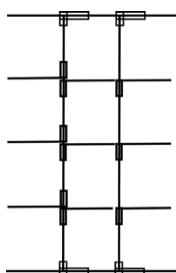

# 500614  
MED-insert ISO  
400x600x100 mm  
12 modules  
3 longitudinal rows  
9 dividers.

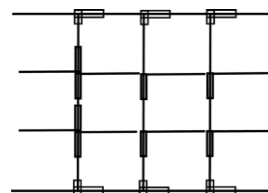

# 500619  
MED-insert ISO  
600x400x100 mm  
12 modules  
4 transversal rows  
8 dividers.

## ■ Plastic ABS slides of ISO trays

**Distinctive features:**

- Material: grey ABS plastic (resistant to scratches and dirt).
- Trays may be fixed in the pulled-out position (if there are stoppers available).
- Quick installation inside cabinets of the “Pharmlogistics” series (no extra fasteners required).

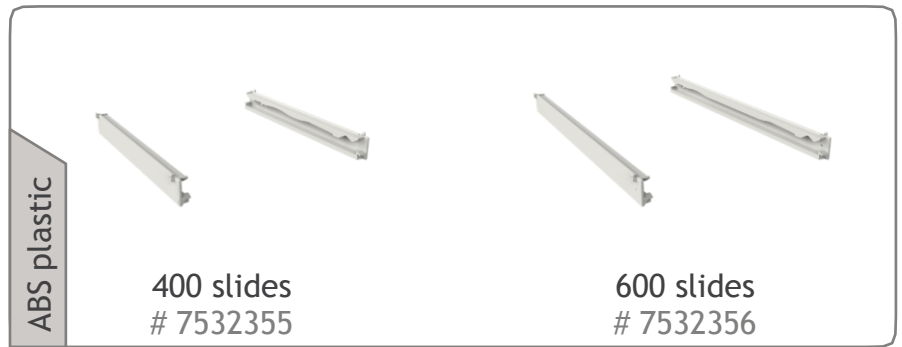

## ■ Metal slides of ISO trays

**Distinctive features:**

- Material: metal and polymer powder coating.
- These items are suitable for usage in cabinets and carts of double-sided access.
- Installation on the frame is carried out by means of clips.

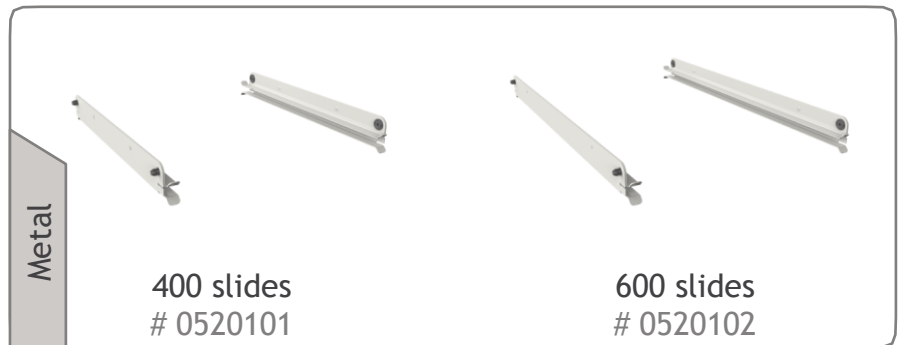

## ■ Wall-mounted ABS panels of ISO trays

**Distinctive features:**

- Material: grey ABS plastic (resistant to scratches and dirt).
- These items are suitable for usage in cabinets made of laminated chip board (they protect walls and convenient for sanitary treatment).
- Installation on the body shall be carried out by means of self-tapping screws. Panel height: 640 mm (2x320 mm).

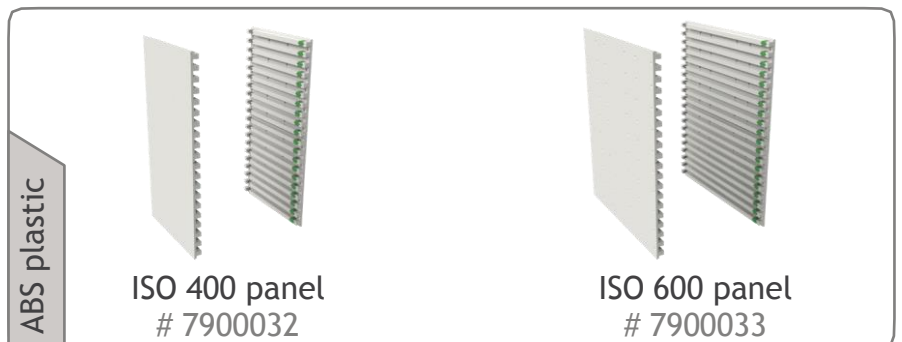

## Telescopic slides of ISO trays ■



# 7930102  
Full-extension ISO  
400 slides.



# 7930101  
Full-extension ISO  
600 slides.



# 7930104  
Full-extension ISO  
400 slides with  
door closers.

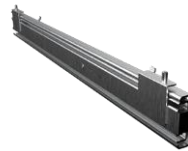

# 7930103  
Full-extension ISO  
600 slides with  
door closers.



# 7930905 (630 mm)  
# 7930906 (952 mm)  
# 7930907 (1890 mm)  
Mounting rail for  
cabinets made of  
laminated chipboard.



# 7930155  
Passing ISO 600  
slides of double  
extension.



# 0520201  
ISO 400 adaptor to  
be mounted on a  
metal frame.

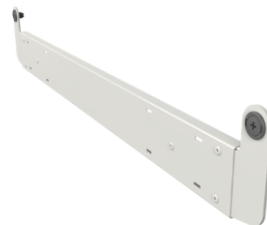

# 0520202  
ISO 600 adaptor to  
be mounted on  
a metal frame.

Metal



## Sliding trays

### Distinctive features:

- Material: HPL plastic/ laminated chipboard with 2 mm PVC edge.
- Quick-detachable design (for installation on slides or ISO wall-mounted panels).
- The items are provided stoppers (they may be used as pull-out tables).

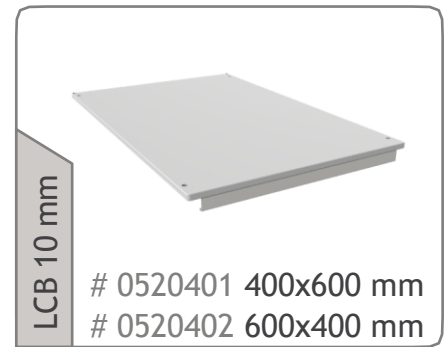
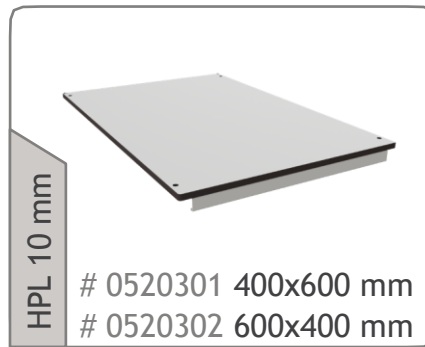

## Fixed trays (adjustable type)

### Distinctive features:

- Material: metal and polymer powder coating/ stainless steel (AISI grade).
- These items are convenient for placing large-size packs, boxes, and storage containers.
- Installation on the frame shall be performed by means of clips.

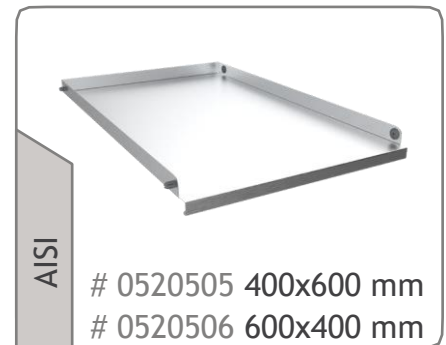
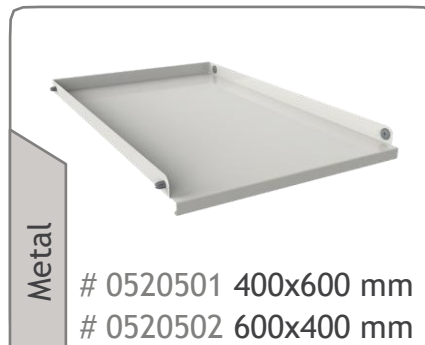

## Storage boxes with handles

### Distinctive features:

- Material: transparent polystyrene, which is resistant to sanitary treatment.
- Sealed body. Boxes are provided with convenient handles and removable dividers.
- Three sectional options: width x depth = 91x81 mm, 132x100 mm, 183x81 mm.

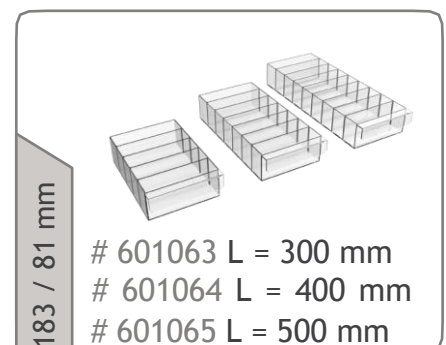
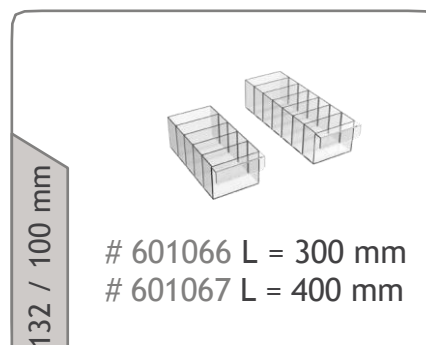
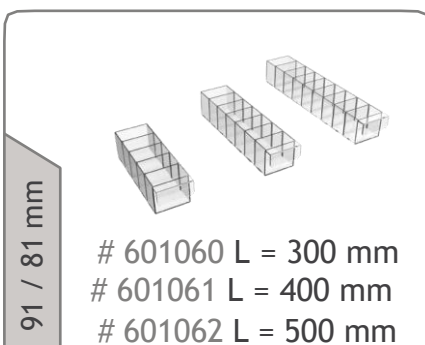



**Distinctive features:**

- Material: metal and rilsan coating (increased resistance to chips and sanitary treatment).
- These items are suitable for usage in sterilization cabinets. Size corresponds to ISO.
- Option to apply dividers: yes.

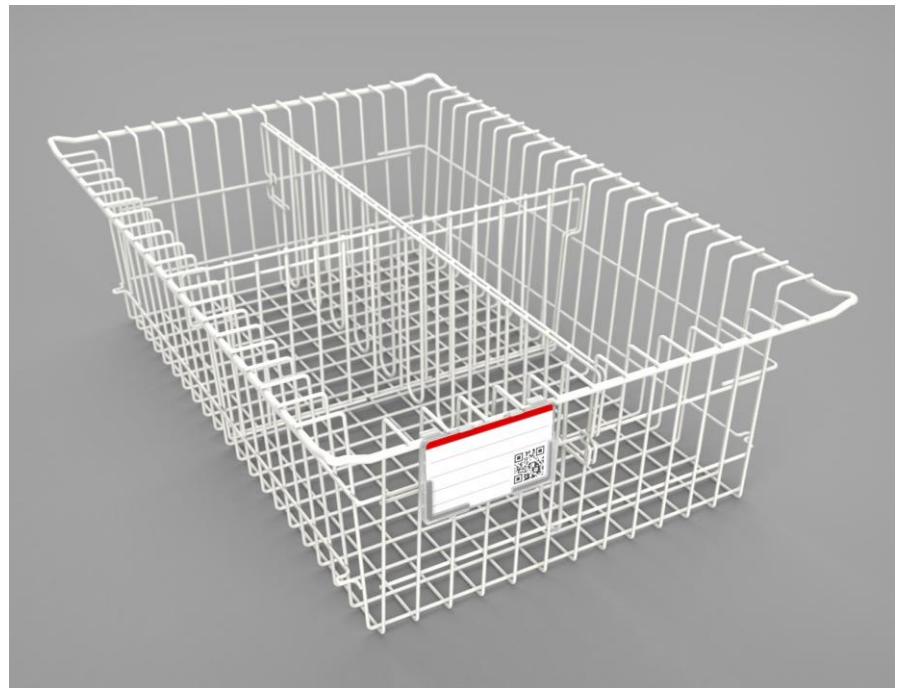
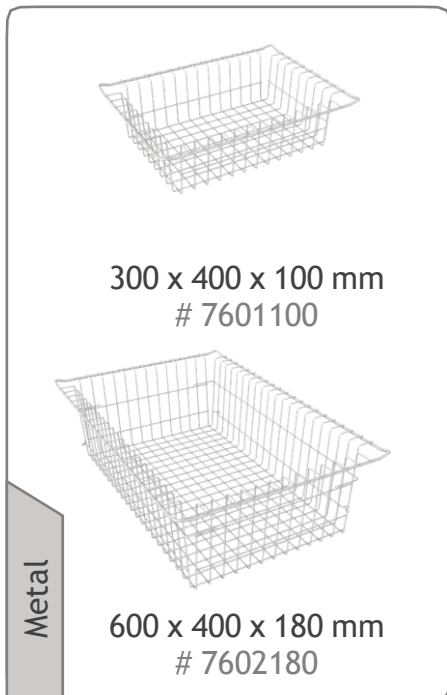

**Dividers of ISO-M baskets (metal) ■**

**Distinctive features:**

- Material: metal and rilsan coating (increased resistance to chips and sanitary treatment).
- Quick-detachable adjustable dividers (spacing: 25 mm).

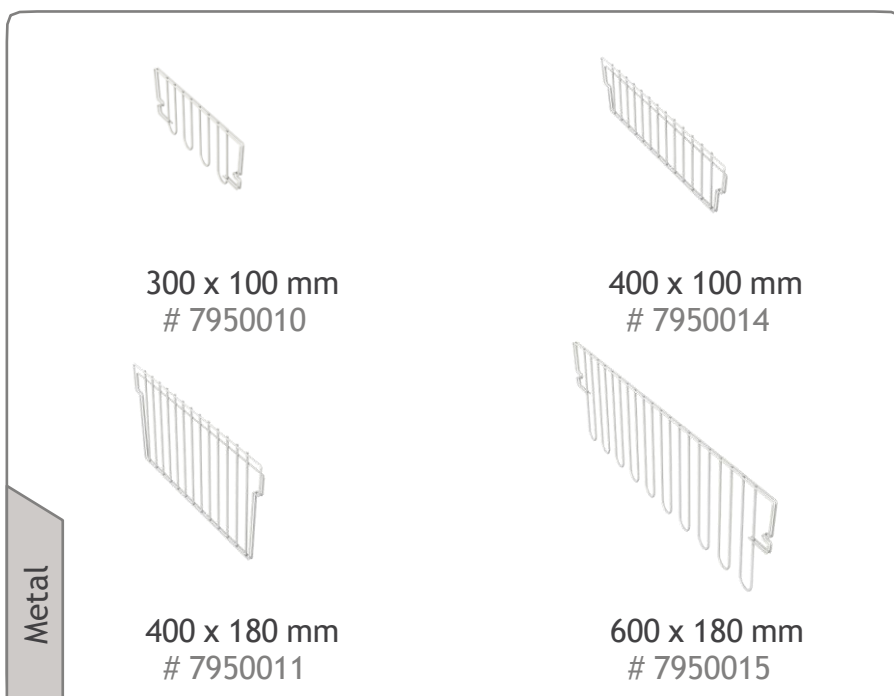





1 : 16



Short insight of new series of furniture by  
Aybolit Trading Company



29 : 20



New “Pharmlogistics” series of furniture by  
Aybolit Trading Company (detailed  
review)

**Aybolit Trading Company**

603146, 68 Kuznechikhinskaya  
Street, Nizhny Novgorod, Russia.  
Telephone: +7 (831) 417-89-98  
Web-site: [www.aybolit2000.ru](http://www.aybolit2000.ru)



Instagram **tdaybolit**